

INSTALLATION AND MAINTENANCE INSTRUCTIONS INDUSTRIAL TANK BLANKETING REGULATORS BKR – BKV

GENERAL

- These instructions must be carefully read before any work involving products supplied by VALSTEAM ADCA ENGINEERING S.A. is undertaken.
- The installation procedure is a critical stage in a life of a valve and care should be taken to avoid damage to the valve or equipment.
- Tank Blanketing valves are designed to give accurate control of down-stream pressures. These give their maximum performance only when the equipment associated with them is correctly sized and installed in accordance with our recommendations.

Note:

- Current regional safety regulations should be taken into account and followed, while doing the installation and maintenance work.
- Handling, installation and maintenance work must be carried out by trained personnel. A supervisor must follow and check all activities.
- For the problems that cannot be solved with the help of these instructions, please contact the supplier or the manufacturer.
- The manufacturer reserves the right to change the design and material of this product without notice.



ATTENTION

- If malfunction of any other equipment or system operation failure may result in a dangerous overpressure, over temperature or even vacuum condition, a safety device must be included in the system to prevent such situations.
- At start up, the presence of small particles in the fluid (dirt, scale, weld splatters, etc) may cause an imperfect closure of the seat. If this occurs, proceed to an accurate cleaning.
- Do not touch the equipment without appropriate protection during working operation because it may conduct heat if the used fluid is at high temperature.
- Before starting maintenance be sure that the equipment is not pressurized or hot.
- Personal injury, equipment damage, or leakage due to escaping accumulated gas or outside bursting of pressure-containing parts may result if this gas blanketing system is overpressured or installed the limits given in the specifications parts section and on the appropriate nameplate, or where conditions exceed any ratings of the adjacent piping or piping connections.
- The equipments must be used within the working temperature and pressure limits laid down for them, otherwise they may fail (refer to nameplate and/or IS- Information Sheet).
- Do not remove the marking on the valve. Serial number and other useful information is stamped on the valve.

CLEANING AND PACKING

- This equipment is packed by proper machine with a special film used by food industry.
- These equipments are degreased and cleaned ultrasonically.

TRANSPORT AND STORAGE



ATTENTION

- Valves must be stored with the adjusting spring relaxed.
- Handling and lifting of materials should be made with adequate equipments.
- The valves and equipments should be protected from impacts and forces during transportation and storage.
- The manufacturer doesn't assume the responsibility of damaged equipments due to inappropriate handling during the transportation and storage.

INSTALLATION



ATTENTION

- Prior to install check that the product is suitable for the intended application: materials and pressure/temperature ratings.
- Before to install remove plastic covers placed on flanges or connection ends. The equipment has an arrow or Inlet/Outlet designations. Be sure that it will be installed on the appropriate direction.
- Take care with jointing material to ensure that none may be permitted to block or enter the valve.
- The reducing valve pipework should be properly supported and free from strain and it should not be subjected to undue surges of pressure.
- Valve mountings such as actuators, handwheels, hoods must not be used with other purpose than the one they were built for (e.g. climbing aids or as connecting points for lifting gear)
- For the problems that cannot be solve with the help of this instructions, please contact the supplier or the manufacturer.

For installations where gas and condensate can be present, we strongly recommend a proper drainage of the system and the valve is positioned where condensation is unable to collect.

Installation area requirements:

- The installation area should have easy access and provide enough space for maintenance and removing operations.
- The installation area should have the necessary firing system to prevent damage of the equipment due to over temperature/pressure cause by fire.

MAINTENANCE

- We recommend that the BKR and BKV to be serviced as necessary. The valves should be checked periodically (at least yearly), to verify that they are operating correctly and to clean the internal parts and screen (if any).
- Visually inspect the unit for any leakage, ensure tight connections, tight seals, and safe operation.
- When reassembling make sure that all gasket faces are clean and always use a new gasket. Tighten cover bolts uniformly in a diagonal sequence.
- In case of clamp connections do not over-tighten them, because that can damage the gasket.

- If there is evidence of leakage or unstable internal action, consult our Sales Office.
- Maintenance should proceed as follows:
 1. Isolation valves should be closed and the pressure and temperature must be atmospheric.
 2. Remove sanitary clamps or other type of connection used.
 3. Execute the maintenance work.
 4. Replace and tighten the clamps, (don't forget to substitute the gasket).

CE MARKING (PED - European Directive 97/23/EC)	
PN 16	Category
DN 25 - 1"	SEP - art. 3, paragraph3

LIMITING CONDITIONS		
Valve model	BKR	BKV
Body design conditions	PN 16	PN 16
Max.upstream pressure	6 bar	6 bar
Max.downstream pressure	500 mbar	5 mbar
Min.downstream pressure	5 mbar	500 mbar
Max.design temperature *	130 °C	130 °C

*Other on request.

Supply 1 – 6 bar Typical installation

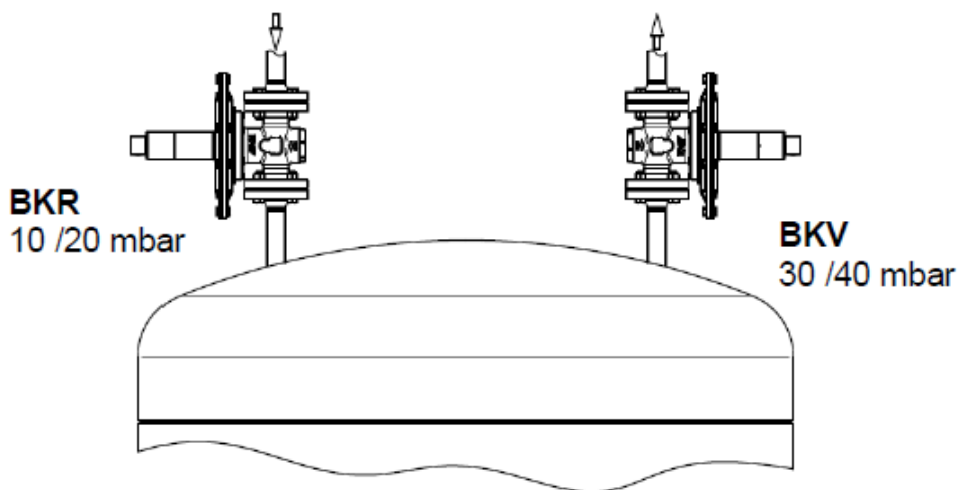

**Blanketing with overpressure
Blanketing valves are not substitute
of safety valves or vacuum relief valves**



ATTENTION

- **LOSS OF WARRANTY:** Total or partial disregard of above instructions involves loss of any right to warranty.