

INSTALLATION AND MAINTENANCE INSTRUCTIONS PRESSURE REDUCING VALVES PRV30 – PRV31

GENERAL

- These instructions must be carefully read before any work involving products supplied by VALSTEAM ADCA ENGINEERING S.A. is undertaken.
- The installation procedure is a critical stage in a life of a valve and care should be taken to avoid damage to the valve or equipment.
- Reducing valves are designed to give accurate control of down-stream pressures. They give their maximum performance only when the equipment associated with them is correctly sized and installed in accordance with our recommendations.

Warning!

- If malfunction of any other equipment or system operation failure may result in a dangerous overpressure, over temperature or even vacuum condition, a safety device must be included in the system to prevent such situations.
- At start up, the presence of small particles in the fluid (dirt, scale, weld splatters, etc) may cause an imperfect closure of the seat. If this occurs, proceed to an accurate cleaning.
- Do not touch the equipment without appropriate protection during working operation because it may conduct heat if the used fluid is at high temperature.
- Before starting maintenance be sure that the equipment is not pressurized or hot.
- The equipments must be used within the working temperature and pressure limits laid down for them, otherwise they may fail (refer to nameplate and/or IS- Information Sheet).
- Do not remove the nameplate attached to the equipment. Serial number and other useful information is stamped on it.
- The valve is not suitable for oxygen service.

INSTALLATION



ATTENTION

- Prior to install check that the product is suitable for the intended application: materials and pressure/temperature ratings.
- Before to install remove plastic covers placed on flanges or connection ends. The equipment has an arrow or Inlet/Outlet designations. Be sure that it will be installed on the appropriate direction.
- Take care with jointing material to ensure that none may be permitted to block or enter the valve.
- Reducing valves are recommended to be fitted with the centre line of the valve in a vertical position to ensure that the best results are obtained.
- An ADCA pipeline strainer should be installed upstream of the valve to protect from dirt which could damage the valve or cause mal-functioning.
- The reducing valve pipework should be properly supported and free from strain and it should not be subjected to undue surges of pressure.

For installations where gas and condensate can be present, we strongly recommend that the reducing valve is positioned where condensation is unable to collect or that, alternatively, separators and steam traps are fitted so that the pipework drains correctly. The start up condition should be considered.



Installation area requirements:

- The installation area should have easy access and provide enough space for maintenance and removing operations.
- The installation area should have the necessary firing system to prevent damage of the equipment due to over temperature/pressure cause by fire.

MAINTENANCE

- We recommend that the pressure reducing valves to be serviced as necessary. Pressure reducing valves should be checked periodically (at least yearly), to verify that they are operating correctly and to clean the internal parts and screen (if any).
- When reassembling make sure that all gasket faces are clean and always use a new gasket. Tighten cover bolts uniformly in a diagonal sequence.
- Valves in store for long periods should have their adjusting spring relaxed.
- For further information refer to the relevant PRV brochure or consult our Sales Office.

CE MARKING (PED - European Directive 97/23/EC)	
PN63	Category
DN15 to DN32	SEP - art. 3, paragraph3
DN40 to DN50	1 (CE Marked)

LIMITING CONDITIONS	PRV30SS	PRV31SS
Body design conditions	PN63	PN63
Max. upstream pressure	50bar	50bar
Max. downstream pressure	15bar	50bar
Min. downstream pressure	0,2bar	3bar
Temperature range*	-20° to 90°C	-20° to 90°C
Maximum reducing ratio	40:1	15:01

*Higher temperatures on request depending on the type of seals and diaphragm used

Recommended limit of operation (°C)						
EPDM (E)	NBR (N)	VITON (V)	PTFE (T)			
130°	95°	180°	180°			
Pressure ranges (bar)						
Spring Nr.	1	2	3	4	5	6
PRV30SS	0,2-1,5	0,3-3	0,8-8	1,5-15	-	-
PRV31SS	-	-	-	-	3 - 30	5 - 50

It is preferable to select a range spring where the desired reduced pressure is at upper end of range.

USEFUL NOTES ON VALVE AND PIPE SIZING

If the flow is unknown it's possible to estimate it based on pipe size or equipment heat requirements - please consult.



PARTS LIST FOR PRV30SS – PRV31SS PRESSURE REDUCING VALVES

CODE	DESIGNATION	VALVE SIZE DN	POS.NR.	QTY.
VR.9305.015	PRV30SS Diaphragm rubber / teflon	15 - 20	10,11	1 set
VR.9305.025	PRV30SS Diaphragm rubber / teflon	25 - 32	10,11	1 set
VR.9305.040	PRV30SS Diaphragm rubber / teflon	40 - 50	10,11	1 set
VR.9306.015	PRV30SS Diaphragm stainless steel	15 - 20	10	1 set
VR.9306.015	PRV30SS Diaphragm stainless steel	25 - 32	10	1 set
VR.9306.025	PRV30SS Diaphragm stainless steel	40 - 50	10	1 set
VR.9315.015	PRV31SS 30 bar Piston O-Ring NBR	15 - 20	9A	1 set
VR.9316.015	PRV31SS 50 bar Piston O-Ring NBR	15 - 20	9A	1 set
VR.9315.025	PRV31SS 30 bar Piston O-Ring NBR	25 - 32	9A	1 set
VR.9316.025	PRV31SS 50 bar Piston O-Ring NBR	25 - 32	9A	1 set
VR.9315.040	PRV31SS 30 bar Piston O-Ring NBR	40 - 50	9A	1 set
VR.9316.040	PRV31SS 50 bar Piston O-Ring NBR	40 - 50	9A	1 set
VR.9305.115*	PRV30-31 Valve plug / spring / gasket	15 - 20	4,5,6,6A,7,8	1 set
VR.9305.125*	PRV30-31 Valve plug / spring / gasket	25 - 32	4,5,6,6A,7,8	1 set
VR.9305.140*	PRV30-31 Valve plug / spring / gasket	40 - 50	4,5,6,6A,7,8	1 set
VR.9305.315	PRV30SS Regulating spring 0,2 - 1,5 bar	15 - 20	15	1 set
VR.9305.415	PRV30SS Regulating spring 0,3 - 1 bar	15 - 20	15	1 set
VR.9305.515	PRV30SS Regulating spring 0,8 - 8 bar	15 - 20	15	1 set
VR.9305.615	PRV30SS Regulating spring 1,5 - 15 bar	15 - 20	15	1 set
VR.9305.325	PRV30SS Regulating spring 0,2 - 1,5 bar	25 - 32	15	1 set
VR.9305.425	PRV30SS Regulating spring 0,3 - 1 bar	25 - 32	15	1 set
VR.9305.525	PRV30SS Regulating spring 0,8 - 8 bar	25 - 32	15	1 set
VR.9305.625	PRV30SS Regulating spring 1,5 - 15 bar	25 - 32	15	1 set
VR.9305.340	PRV30SS Regulating spring 0,2 - 1,5 bar	40 - 50	15	1 set
VR.9305.440	PRV30SS Regulating spring 0,3 - 1 bar	40 - 50	15	1 set
VR.9305.540	PRV30SS Regulating spring 0,8 - 8 bar	40 - 50	15	1 set
VR.9305.640	PRV30SS Regulating spring 1,5 - 15 bar	40 - 50	15	1 set
VR.9315.515	PRV31SS Regulating spring 3 - 30 bar	15 - 20	15	1 set
VR.9315.615	PRV31SS Regulating spring 5 - 50 bar	15 - 20	15	1 set
VR.9315.525	PRV31SS Regulating spring 3 - 30 bar	25 - 32	15	1 set
VR.9315.625	PRV31SS Regulating spring 5 - 50 bar	25 - 32	15	1 set
VR.9315.540	PRV31SS Regulating spring 3 - 30 bar	40 - 50	15	1 set
VR.9315.640	PRV31SS Regulating spring 5 - 50 bar	40 - 50	15	1 set

* Suffix : P-PTFE ; N - NBR ; E - EPDM ; V - Viton

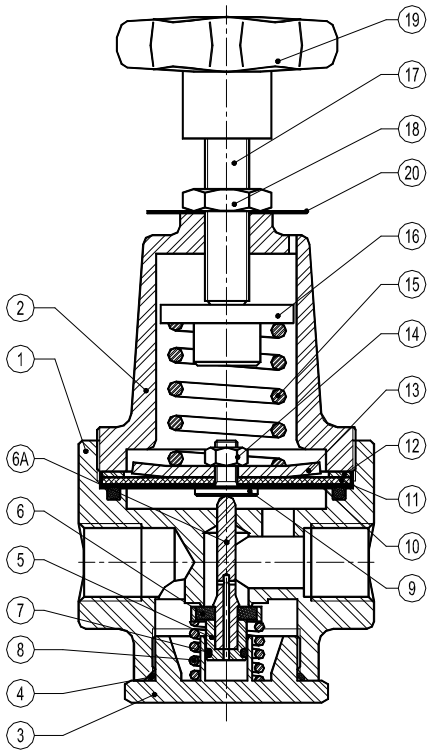

PRV30SS DN15 - DN20

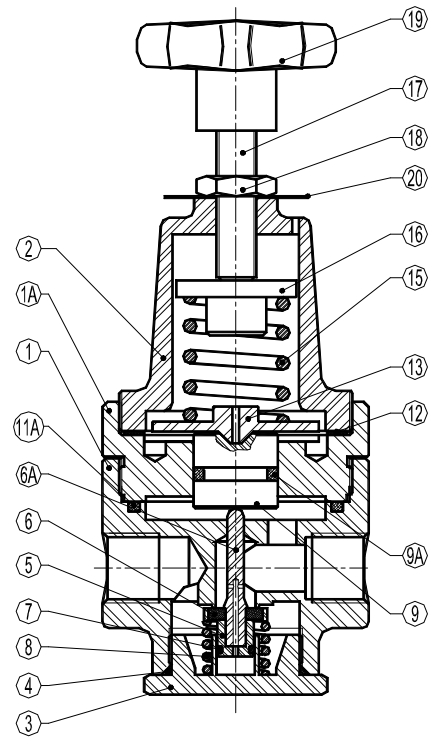

PRV31SS DN15 - DN20

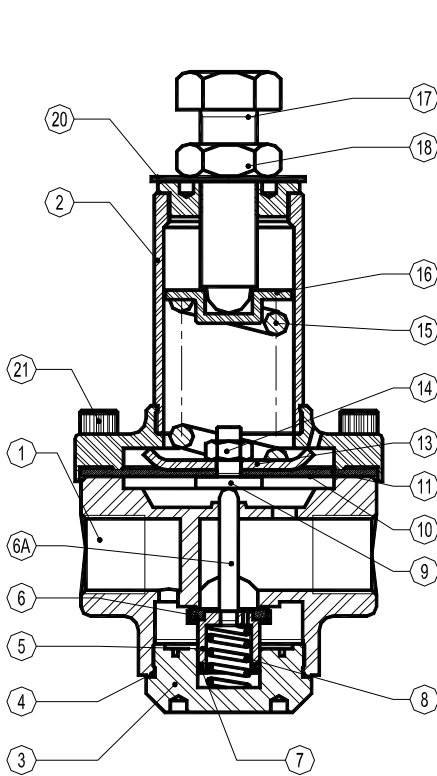

PRV30SS DN25 - DN50

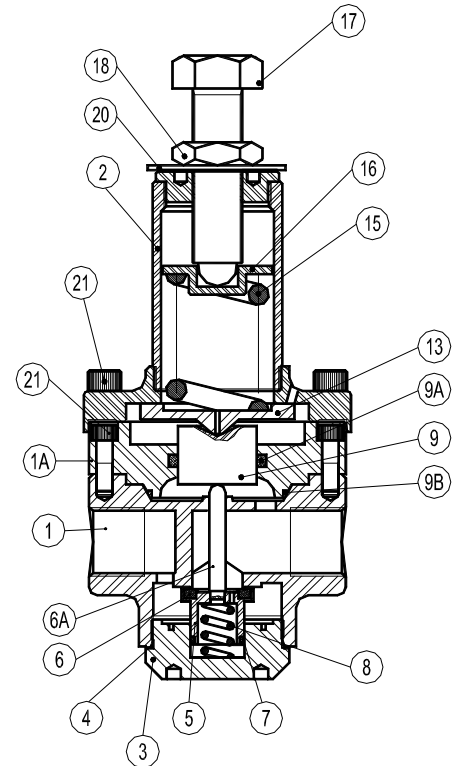

PRV31SS DN25 - DN50



STEAM EQUIPMENT



ATTENTION

- **LOSS OF WARRANTY:** Total or partial disregard of above instructions involves loss of any right to warranty.