

PRESSURE SUSTAINING VALVE PS45 (EN)

DESCRIPTION

The ADCA PS45 series pressure sustaining valves are single seat bellows sealed controllers, operating without auxiliary energy, designed for use on steam, compressed air, industrial inert gases and liquids compatible with the construction.

They are particularly suitable for sustaining steam pressure in all energy and process systems where upstream pressures should be kept constant.

OPERATION

Pressure sustaining is achieved by means of variable throttling of the inlet flow at the valve seat by variation of the flow area between seat and disc. The inlet pressure which is transmitted through the sensing line to the diaphragm or piston chamber counteracts the spring force acting on the valve spindle and controls the valve aperture corresponding to the spring setting and thus to the required inlet pressure.

MAIN FEATURES

Specially designed high durability bellows, providing pressure balancing and friction less plug stem.

Robust construction (fit-and-forget).

Suitable for use with high pressure turndowns.

Interchangeable actuators

OPTIONS: Soft sealing for steam
Nitrile rubber soft seated version for air and gas applications where tight shut-off is required.

USE: Steam, compressed air and other gases and liquids compatible with the construction.

AVAILABLE MODELS: PS45G and PS45GT or N – PN16 SG iron
PS45S and PS45ST or N – PN16 Cast steel
PS45S and PS45ST or N – PN40 Cast steel
PS45I and PS45IT or N – Stainless Steel
(All wetted parts free of non-ferrous metal or in St.Steel.).

Suffix T : Soft seated with PTFE/GR

Suffix N : soft seated with nitrile rubber

SIZES: DN 15 to DN 100

CONNECTIONS PS45G Flanged EN 1092-2 PN16
PS45S or I Flanged EN 1092-1 PN16 – PN40
ANSI B16.5 flanged connections on request

INSTALLATION: Horizontal installation.
An “Y” strainer, steam separator and steam trap should be provided upstream the valve.
See IMI, installation and maintenance instructions.

Sustaining valves are not substitute of safety valves or vacuum relief valves



CE MARKING (PED - European Directive)

PN 16	PN 40	Category
DN15 to DN50	DN15 to DN32	SEP - art. 3, paragraph3
DN65 to DN100	DN40 to DN100	1 (CE Marked)

LIMITING CONDITIONS

	PS45G PS45S	PS45S	PS45I	PS45GT PS45ST	PS45ST	PS45IT	PS45GN* PS45SN*	PS45SN *	PS45IN *
Body design conditions	PN16	PN40	PN40	PN16	PN40	PN40	PN16	PN40	PN40
Max.upstream pressure **	13 bar	13 bar	13 bar	13 bar	13 bar	13 bar	13 bar	13 bar	13 bar
Max.downstream pressure	13 bar	13 bar	13 bar	13 bar	13 bar	13 bar	13 bar	13 bar	13 bar
Min.downstream pressure	0,15 bar	0,15 bar	0,15 bar	0,15 bar	0,15 bar	0,15 bar	0,15 bar	0,15 bar	0,15 bar
Max.operating temperature	200°C	250°C	250°C	200 °C	200 °C	200 °C	80 °C	80 °C	80 °C
Max.reducing ratio	25:1	25:1	25:1	25:1	25:1	25:1	10:1	10:1	10:1
Rangeability	10:1	10:1	10:1	10:1	10:1	10:1	10:1	10:1	10:1
Max.cold hydraulic test	24 bar	25 bar	25 bar	24 bar	25 bar	25 bar	24 bar	25 bar	25 bar
Max.hyd. factory valve body test	24 bar	60 bar	60 bar	24 bar	60 bar	60 bar	24 bar	60 bar	60 bar

* Suffix N : - a maximum turndown ratio 10:1 should be observed. Other soft materials on request.

** Others on request with bellows or piston actuator

DIMENSIONS (mm)

VALVE				ACTUATOR		
SIZE DN	A	B	WGT. Kgs	TYPE	C	WGT. Kgs
15	130	440	12,7	A1	172	4,3
20	150	440	12,7	A11	172	4,3
25	160	440	13,7	A2	220	7,3
32	180	445	15,7	A21	220	7,3
40	200	445	17,7	A3	282	11,3
50	230	540	25,7	A4	340	16,3
65	290	540	29,7			
80	310	610	36,7			
100	350	650	53,7			

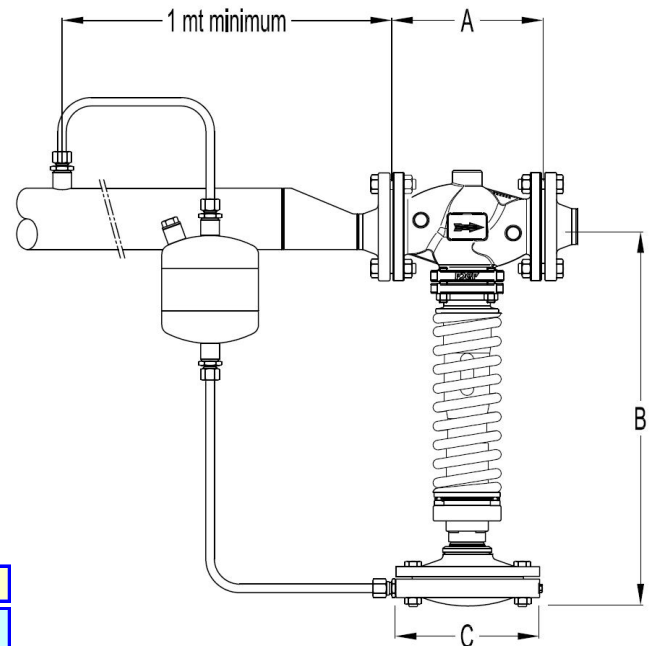

MATERIALS

POS.	DESIGNATION	MATERIAL
1	Valve body PS45G	GJS-400-15 / 0.7040
1	Valve body PS45S	A216WCB / 1.0619
1	Valve body PS45I	CF8M / 1.4408
2	Piston body PS45G and S	GJS-400-15 / 0.7040
2	Piston body PS45I	GJS-400-15 / 0.7040 Nickel plated
3	Valve seat	HARDENED ST. STEEL
4	* Valve disc	HARDENED ST. STEEL
4	* Soft valve disc	AISI 304/1.4301 ;NBR (PTFE/GR,etc)
5	Guide	AISI 304 / 1.4301
6	* Bellows	AISI 316 Ti / 1.4571
7	* Diaph. chamber PS45G/S	GJL-250 / 0.6025
7	* Diaph. Chamber PS45I	CF8M / 1.4408
8	Spindle	AISI 304 / 1.4301
9	Regulating spring	SPRING STEEL
10	* Impulse line PS45G and S	COPPER
10	* Impulse line PS45I	AISI 316 / 1.4401
11	* Cond. vessel a) PS45S	S235JRG2 / 1.0038
11	* Cond. vessel a) PS45I	AISI 316 / 1.4401

* Available spare parts.

a) Not necessary when in operation with low temperature compressed air or water.

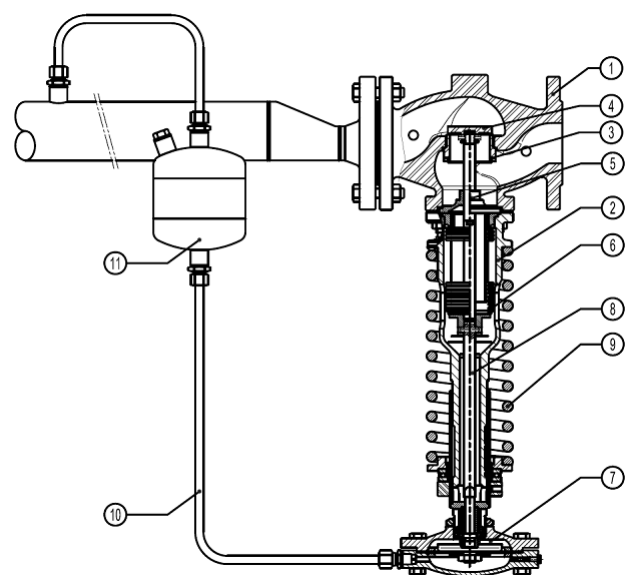

FLOW RATE CAPACITY Kvs m ³ /h								
VALVE SIZE								
DN 15	DN 20	DN 25	DN 32	DN 40	DN 50	DN 65	DN 80	DN 100
4,8	6,9	9,1	11,8	14,4	26,5	51,5	79,5	129,5

ORDER REQUIREMENTS: For the optimum selection of valve and actuator it is recommended that valve spring and actuator selection is made by the factory or an authorized distributor. For the proper selection following data should be supplied:

- Type of fluid and temperature (not necessary in case of saturated steam)
- Maximum operating pressure
- Required opening pressure
- Flow rate (maximum and minimum)

How to order: PS45G DN32 PN16 valve complete with spring Nr.60, type A-2 actuator, condensate vessel and copper tube impulse line.

HOW TO SIZE (using Kvs): please consult formulas on IS PV10.00 E or consult factory.

INSTALLATION RECOMMENDATIONS

PS45 is designed primarily for steam, compressed air and non inflammable gases. It has limited use for neutral liquids which can produce vibrations and water-hammer. Please consult the factory.

At service conditions where the temperature is more than 100°C it is necessary to protect the diaphragm against overheating by using a seal pot.

Never size the valve according to the pipe diameter in which it has to be fitted but according to the required actual flow .Pipe sizing must also respect the maximum recommended flow velocities according to the medium.

INSTALLATION

Service conditions less than 100°C: with gases the valve is ready to work. In case of liquids the actuator must be filled completely with liquid, so, the vent screw (12) should be open till the water flow without bubbles.

The valve can be installed with the diaphragm pointing upwards or downwards.

Service conditions more than 100°C : Fill the seal pot (11) using a funnel (14) until the water emerges from the actuator vent (12) without bubbles .Close the actuator vent screw (12) and proceed filling the pot until the water reaches the top and close it with the plug. The valve is now ready to work.

The valve must be installed with the diaphragm pointing downwards.

Upstream pressure should be adjusted with the key (13). Compressing the spring, spring force increase and upstream pressure aperture increase. Relaxing the spring, spring force decrease and upstream pressure aperture decrease.

The valve closes when the upstream pressure decreases.

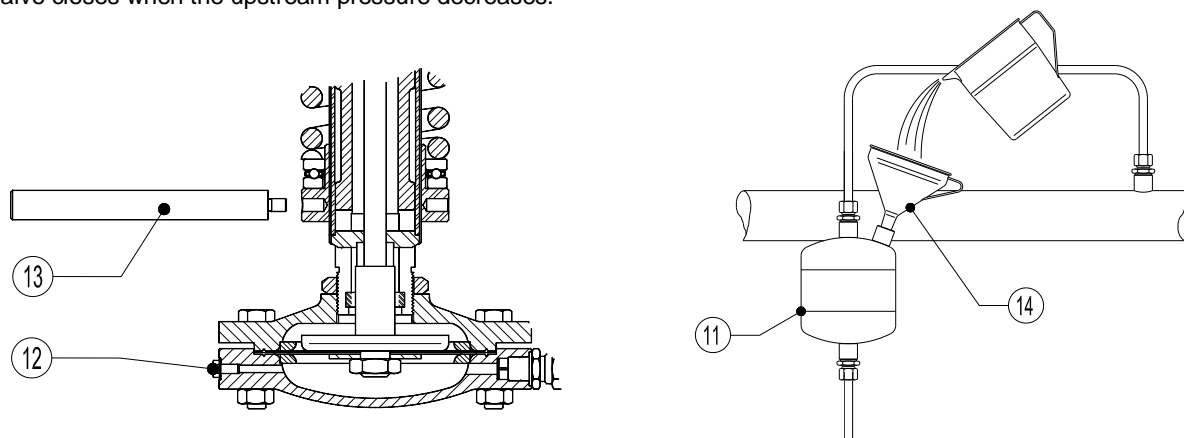

Typical Installation

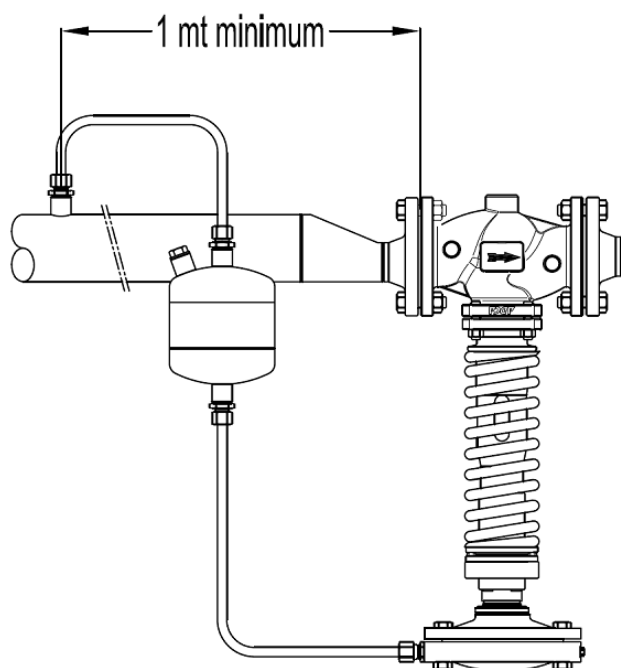
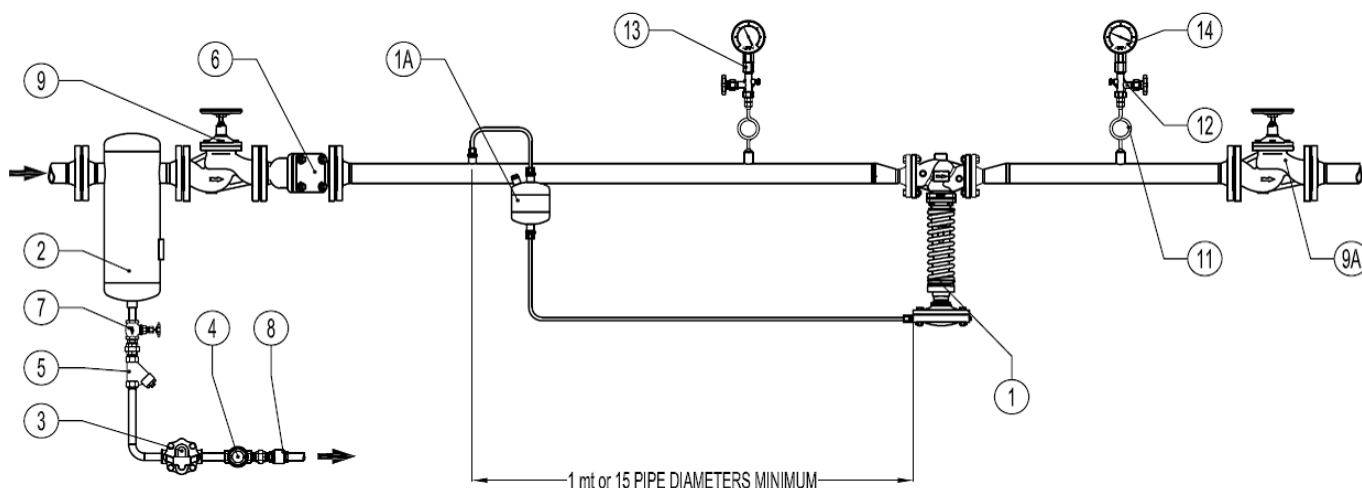

MATERIALS		
POS.	DESIGNATION	MODEL
1	Pressure sustaining valve	ADCA PS45
1A	Water seal pot	POT
2	Humidity separator	ADCA S 25
3	Steam trap	ADCA FLT series
4	Sigh glass	ADCA SW 12
5	Y Strainer	ADCA IS 16
6	Y Strainer	ADCA IS16F
7	Stop valve	ADCA GV32B
8	Check valve	ADCA RT
9	Stop valve	ADCA VF16
9A	Stop valve	ADCA VF16
11	Coil	ADCA GSC-40
12	Gauge cock	ADCA GC-400
13	Upsteam pressure gauge	ADCA MAN-100
14	Downstream pressure gauge	ADCA MAN-100

Remarks:

PN ratings and materials according to the operating pressures.

* The balance pipe connection is recommended to enter upstream pipe at a minimum of 1 meter from valve. Installation instructions are available (IMI-PS45) and typical assembling drawing.

Special assembling designs may be produced on request.