

## TANK BLANKETING REGULATORS BKRI2 ( Low pressure regulator )

**DESCRIPTION**

Tank blanketing valves are commonly used in tank storage systems to prevent and protect against explosions (avoiding flammable liquids being vented from vessel), to control product contamination against external air that may fill the vapour space, to reduce evaporation losses (consequently product losses), to reduce internal corrosion (caused by air and moisture) and to prevent vacuum condition.

The blanketing process consists in covering the stored medium, usually a liquid, with a gas (normally N<sub>2</sub>).

**MAIN FEATURES**

Compact design.

No rising stem, except when supplied with top cap.

**STANDARD SURFACE FINISH**

Internal wetted parts: ≤ 0,51 micron Ra – SF1.

Body and cover

Internal: machined / as casted.

External: as casted.

Ultrasonic cleaning.

**OPTIONS:**

- Diaphragm leakage line connection.
- Gauge connection on body.
- External pulse line (recommended for low set pressures < 10 mbar or high flow).
- Dome loaded (for higher pressure control).
- Blanketing with vacuum.
- Top cap (adjusting screw sealing).

**USE:**

Compressed air, nitrogen and other gases compatible with the construction.

**AVAILABLE MODELS:**

BKRI2 – Low pressure regulator.

**SIZES:**

DN 15 and DN 25.

**CONNECTIONS:**

Flanged EN 1092-1 PN16.

**OUTLET SPRING RANGES:**

5 to 500 mbar (4000mbar with dome load).

**INSTALLATION:**

Vertical installation recommended (to allow draining) or horizontal as close to process as possible in order to prevent long pipe sections and flow restrictions.

For an economical consumption of blanketing gas, the pressure must be adjusted to remain slightly above than atmospheric pressure, while filling and emptying the vessel.

**ORDER REQUIREMENTS:**

- Type of fluid.
- Maximum operating temperature.
- Inlet pressure and required outlet pressure.
- Capacity (maximum and minimum).



CE MARKING (PED - European Directive)	
PN 16	Category
DN 15 to 25	SEP

CAPACITIES in Nm <sup>3</sup> /h (air) Max. inlet pressure 6 bar - Seat ø 8 mm										
DN	Out. Press. mbar	Inlet Pressure barg								
		0,1	0,5	0,8	1	2	3	4	5	6
15	5 to 10	3,5	18	28	37	56	77	92	111	128
15	10 to 50	3,5	18	28	37	56	77	92	111	128
15	20 to 200	/	18	28	37	56	77	92	111	128
15	50 to 500	/	/	/	37	56	77	92	111	128
25	5 to 10	4	20	32	40	63	85	102	125	140
25	10 to 50	4	20	32	40	63	85	102	125	140
25	20 to 200	/	20	32	40	63	85	102	125	140
25	50 to 500	/	/	/	40	63	85	102	125	140

Outlet pressure should not be more than 50% of inlet ,  
in order to reach the mentioned flow rates.

CAPACITIES in Nm <sup>3</sup> /h (air) Max. Inlet pressure 16 bar - Seat ø 5 mm							
DN	Out. Press. mbar	Inlet Pressure barg					
		2	4	6	8	12	16
15	5 to 10	18	32	43	54	81	106
15	10 to 50	18	32	43	54	81	106
15	20 to 200	18	32	43	54	81	106
15	50 to 500	18	32	43	54	81	106
25	5 to 10	21	35	49	62	90	118
25	10 to 50	21	35	49	62	90	118
25	20 to 200	21	35	49	62	90	118
25	50 to 500	21	35	49	62	90	118

Outlet pressure should not be more than 50% of inlet ,  
in order to reach the mentioned flow rates.

DIMENSIONS (mm) FLANGES EN PN16						
SIZE DN	A	B	C	D	d1	WGT. Kg
15	130	47,5	243,5	230	1/4"	9,7
25	160	57,5	243,5	230	1/4"	10,8

LIMITING CONDITIONS		
Valve model	BKRI2	
Body design conditions	PN 16	
Max.upstream pressure	Seat ø 5	16 bar
	Seat ø 8	6 bar
Max.downstream pressure	500 mbar	
Min.downstream pressure	5 mbar	
Max.design temperature *	130 °C	

\*Other on request.

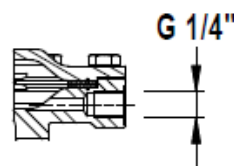
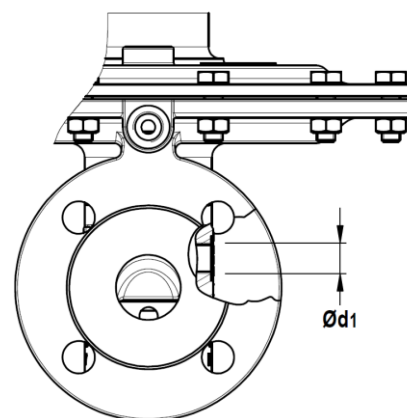
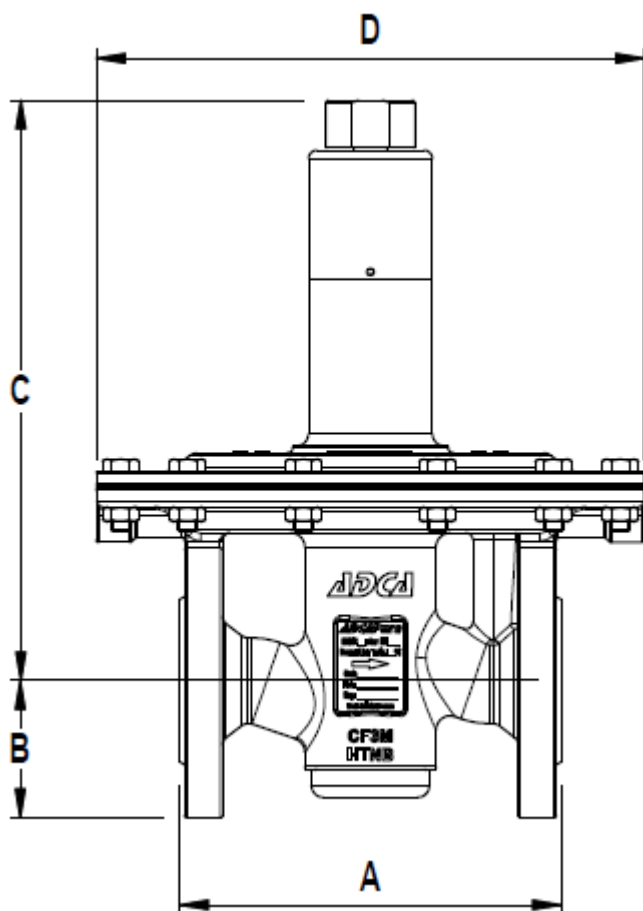

Optional external  
sensing pipe  
connection.

MATERIALS		
POS.	DESIGNATION	MATERIAL
1	Valve body	CF3M / 1.4409
2	Diaphragm top cover	CF3M / 1.4409
3	Seat cover	AISI316L / 1.4404
4	* O-ring	EPDM
5	*Piston	AISI316L / 1.4404
6	* Valve head	AISI316L / 1.4404
7	* O-ring	EPDM
8	*Valve spring	AISI302 / 1.4300 (Polished)
9	Seat	AISI316L / 1.4404
10	* O-ring	EPDM
11	Piston guide	PTFE
12	Stem	AISI316L / 1.4404
13	Stem guide	PTFE
14	Retaining ring	St.steel A2
15	Diaphragm plate	AISI316L / 1.4404
16	* O-ring	EPDM
17	Bolts	St.steel A2-70
18	Nuts	St.steel A2-70
19	Spring cover	AISI316L / 1.4404
20	* Low er diaphragm	PTFE
21	* Upper diaphragm	VITON
22	Diaphragm plate	AISI316L / 1.4404
23	Nut	St.steel A2-70
24	Washer	AISI316 / 1.4401
25	Low er spring guide	AISI316L / 1.4404
26	* Regulating spring	AISI302 / 1.4300
27	Top spring plate	AISI316L / 1.4404
28	Adjustment screw	AISI304 / 1.4301
29	Bearing	Corrosion res. Steel
30	* O-ring	EPDM
31	Regulating nut	AISI316L / 1.4404
32	Ext. bow ed shaft ring	Stainless steel
33	Cover nut	Plastic

\* Available spare parts.

Remarks: FDA/USP Class VI seals certificate on request.  
All valves have a serial number. In case of non-standard valves, this number must be supplied if spare parts are ordered.

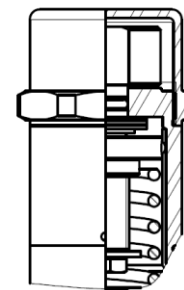
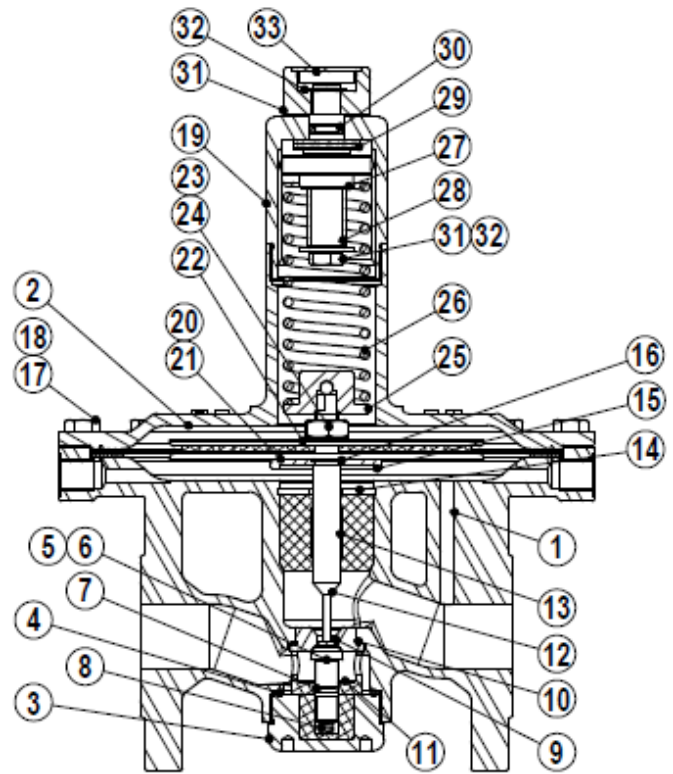

Optional top cap adjusting screw sealing.

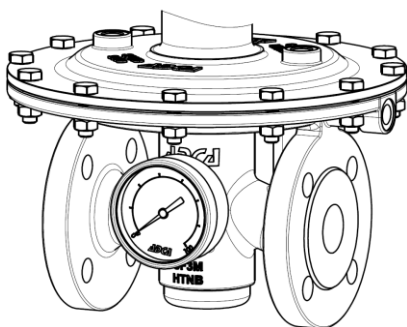

Optional pressure gauge connection.

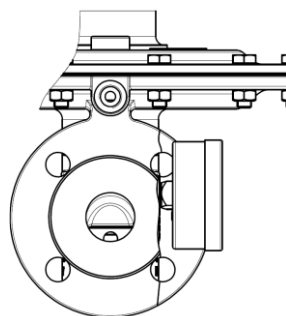

Optional 1/4" diaphragm leakage connection.

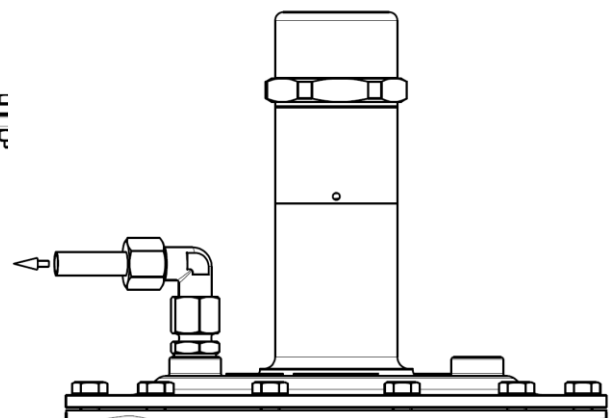

Blanketing valves are not substitute of safety valves or vacuum relief valves.

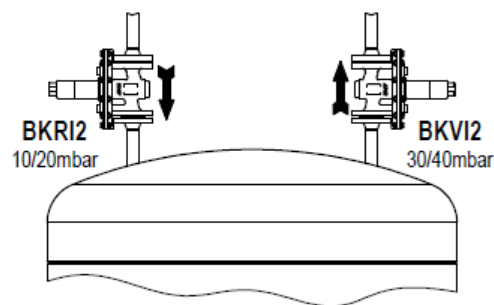
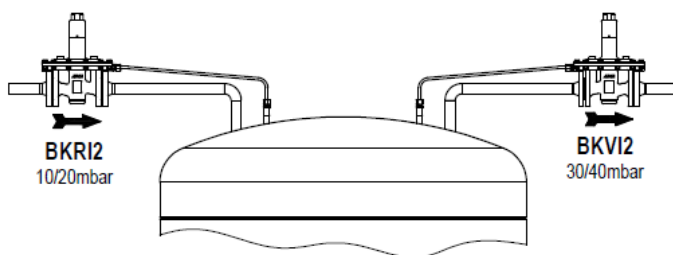
**Typical installation**

**Blanketing with overpressure**

ORDERING CODES BKRI2												
Valve Model	BR	I	0	5	E	E						D 25
BKRI2 - Blanketing low pressure regulation valve	BR											
<b>Body material</b>												
CF3M 1.4409 Stainless steel		I										
<b>Outlet spring range</b>												
5 to 10 mbar			0									
10 to 50 mbar				1								
20 to 200 mbar					2							
50 to 500 mbar						3						
<b>Valve seat orifice</b>												
Seat diameter 5mm				5								
Seat diameter 8 mm					8							
<b>Top cap</b>												
None												(*)
Adjusting screw sealing												T
<b>Valve head</b>												
EPDM												E
<b>Diaphragm material</b>												
PTFE /EPDM												E
<b>Special services / options</b>												
Standard surface finish												(*)
Mechanical polish												1
Electropolishing												2
<b>Gauge port</b>												
Without gauge ports												(*)
Threaded gauge port on the left side (Rel. to the flow direction)												4
Threaded gauge port on the right side (Rel. to the flow direction)												3
Threaded gauge port on both sides												2
<b>Leakage connection</b>												
None												(*)
Diaphragm cover leakage connection in case of diaphragm failure												R
<b>Dome loaded</b>												
None												(*)
Dome loaded for higher pressure control												A
<b>External pulse line</b>												
Internal pulse orifice												(*)
External pulse line												1
<b>Pipe connection</b>												
Flanged EN1092-1 PN16												L
<b>Size</b>												
DN 15												15
DN 25												25
<b>Special valves / Extras a)</b>												E

(\*) Omitted if a standard valve is requested

a) Full description or additional codes have to be added in case of non-standard combination.