

CENTRIFUGAL AIR AND DIRT SEPARATORS

For liquid systems AS – AS/F

DESCRIPTION

The AS centrifugal air and dirt separators are designed for use in the flow line of a hydronic heater or cooling system. The operation is based on the principle of centrifugal force, instead of relying on low velocity separation, offering the advantage of efficient separation in a smaller vessel.

ADCA AS units provides maximum separation efficiency while minimizing space requirements.

The inside strainer protects against any dirt present in the system such as sand, welding residues, etc. The strainer screen position has a particular advantage compared with external pipe strainers because the dirt is removed from the water flow and is collected in the reservoir bottom avoiding pressure drop increasing. Connections are female screwed or flanged.

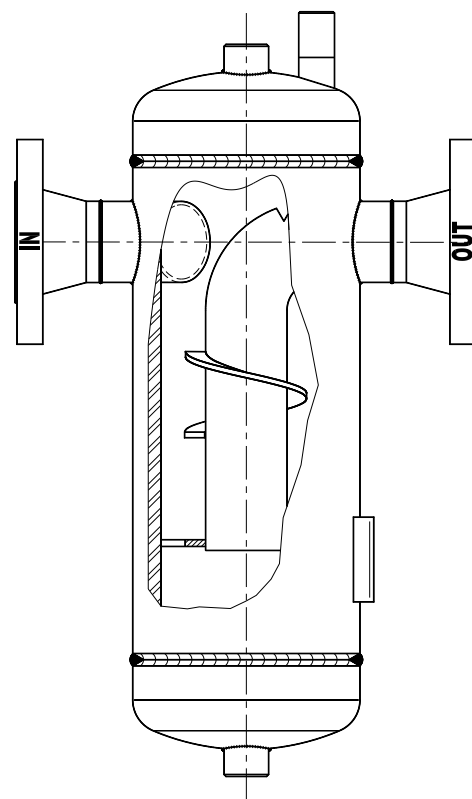

OPTIONS: Galvanised and complete stainless steel construction.

USE: To remove air and dirt in hydronic heating, cooling and pumping systems.

AVAILABLE MODELS:

- AS/S - carbon steel body.
- AS/SZ - zinc plated body.
- AS/SS - stainless steel body
- AS/SF - carbon steel with strainer

SIZES:

- Screwed: DN11/4" to DN2".
- Flanged: DN32 to DN300

CONNECTIONS:

- Female screwed ISO 7/1Rp(BS21)
- Flanged EN 1092-1 or ANSI
- Special flanges upon request.

INSTALLATION:

The AS separators should be installed at the highest temperature and lowest pressure points where solubility is lower.

Ideally they should be installed after boilers or heat exchangers, before chillers and before pump suction.

Horizontal installation always with the drain discharge pointing downwards.

An ADCA AE series air eliminator is recommended to remove the air.

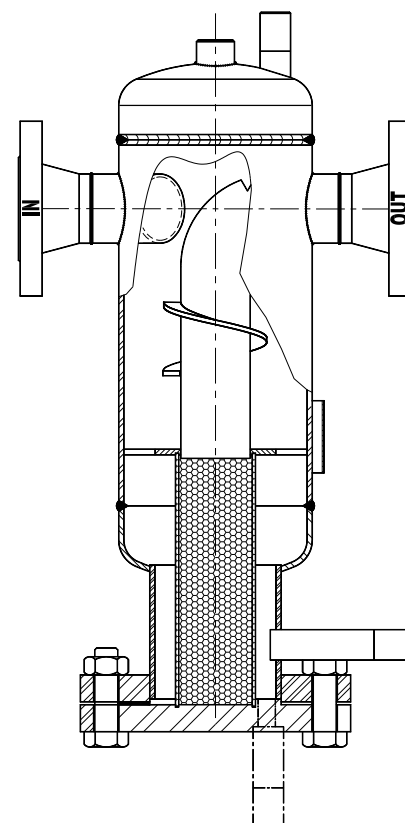



LIMITING CONDITIONS AS/SS **											
Rating	Press. bar	Temp. °C	Rating	Press. bar	Temp. °C	Rating	Press. bar	Temp. °C	Rating	Press. bar	Temp. °C
PN16	16	50	ANSI Cl.150 lbs	16	50	PN25 ANSI CL.300lbs	25	50	PN40 ANSI CL.300lbs	40	50
	14	100		14	100		23	100		37	100
	13	195		13	195		20	216		31	239
	12	250		-	-		17	300		27	300

LIMITING CONDITIONS AS/SS **											
Rating	Press. bar	Temp. °C	Rating	Press. bar	Temp. °C	Rating	Press. bar	Temp. °C	Rating	Press. bar	Temp. °C
PN16	16	50	ANSI Cl.150 lbs	16	50	PN25 ANSI CL.300lbs	25	50	PN40 ANSI CL.300lbs	40	50
	16	100		16	100		25	100		40	100
	13	195		13	195		21	217		32	240
	12	250		-	-		18	300		30	300

Minimum operating temp.: -10°C. Design code: AD-Merkblatt ** Rating according to EN1092:2007.

CE MARKING - GROUP 2 LIQUIDS CATEGORIES								
RATING	SIZE	CAT.	RATING	SIZE	CAT.	RATING	SIZE	CAT.
PN16	DN32 to DN300	SEP	PN25	DN32 to DN250	SEP	PN40	DN32 to DN200	SEP
	-	-		DN300	1		DN250 to DN300	1

CE Marking: This product have been designed for use on water and other liquids which are in Group 2 of the European PED-Pressure Equipment Directive in use and it complies with those requirements. The product carries the CE mark when falling in category 1 and above.

FLANGE CONNECTIONS			
Rating	Sep. SIZE	EN STD.	ANSI STD.
PN16*	DN32 to DN50	EN1092-1 PN40	ANSI B16.5 Cl.150 lbs
PN16	DN65 to DN300	EN1092-1 PN16	ANSI B16.5 Cl.150 lbs
PN25	DN32 to DN150	EN1092-1 PN40	ANSI B16.5 Cl.300 lbs
PN25	DN200 to DN300	EN1092-1 PN25	ANSI B16.5 Cl.300 lbs
PN40	DN32 to DN300	EN1092-1 PN40	ANSI B16.5 Cl.300 lbs

* Flanges EN 1092-1 PN16 and PN40 from DN32 to DN50 has the same number and size of holes.

MATERIALS	
DESIGNATION	MATERIAL
Body	EN10216-2 / P235GH / 1.0325
Heads	EN10028-2 / P265GH / 1.0425
Inlet / Outlet pipes	EN10216-2 / P235GH / 1.0325
EN Flanges	EN10222-2 / P250GH / 1.0460
ANSI flanges	ASTM A105 / 1.0432
Sockets	ASTM A105 / 1.0432
Internals	EN10025-2 / S235JR / 1.0038
Strainer	AISI304 / 1.4301

APPROXIMATE DIMENSIONS (mm)																		
FLANGED EN1092-1 - ANSI																		
SIZE DN	A1 PN16	A PN16	A PN25	A PN40	A 150lbs	A 300lbs	B	C	C1	D	D1	E	F	F1	G	H	VOL. * dm3	WGT ** Kg
32	263	260	260	260	290	306	140	395	495	285	385	110	3/4"	1/2"	1/2"	3/4"	6	13
40	263	260	260	260	294	307	140	435	535	325	425	110	3/4"	1/2"	1/2"	3/4"	6,7	14,3
50	322	310	310	310	341	354	168	505	605	385	485	120	3/4"	1/2"	1/2"	3/4"	11,7	21
65	-	380	394	394	430	442	219	550	670	410	530	140	1"	3/4"	3/4"	1"	19,8	31,5
80	-	400	416	416	440	459	219	610	730	462	582	148	1"	3/4"	3/4"	1"	27	40
100	-	485	511	511	533	553	273	715	835	528	648	187	1 1/4"	3/4"	3/4"	1 1/4"	38	59,8
125	-	535	561	561	605	622	324	845	995	630	780	215	1 1/4"	1"	1"	1 1/4"	54	84
150	-	585	605	605	635	652	356	962	1112	692	842	270	1 1/2"	1"	1"	1 1/2"	79	161
200	-	605	641	657	685	703	406	1170	1320	880	1030	290	1 1/2"	1"	1"	1 1/2"	146	202
250	-	720	756	790	784	815	508	1540	1710	1140	1310	400	1 1/2"	1"	1"	1 1/2"	288	330
300	-	840	868	914	913	944	610	1700	1870	1172	1342	528	1 1/2"	1"	1"	1 1/2"	412	475

* Volume correspond to the class PN16 AS/F design. Classes PN25 and above may have slightly lower volumes.

** Weight correspond to the class PN16 design.

F, F1, H - screw ed drain connection standard. Alternatively can be supplied flanged EN1092-1 or ANSI on the same class of main dimensions. Consult factory for certified dimensions. Dimensions subject to change without notice.

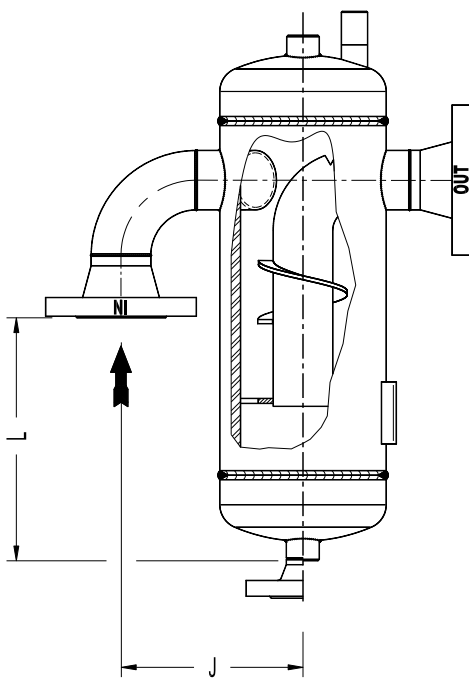
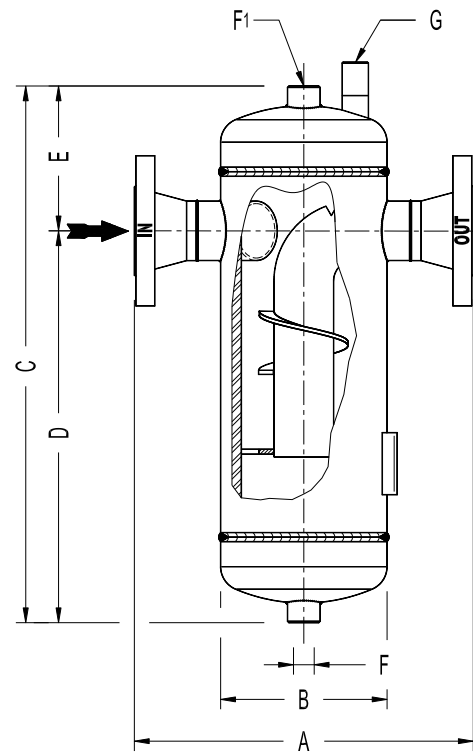
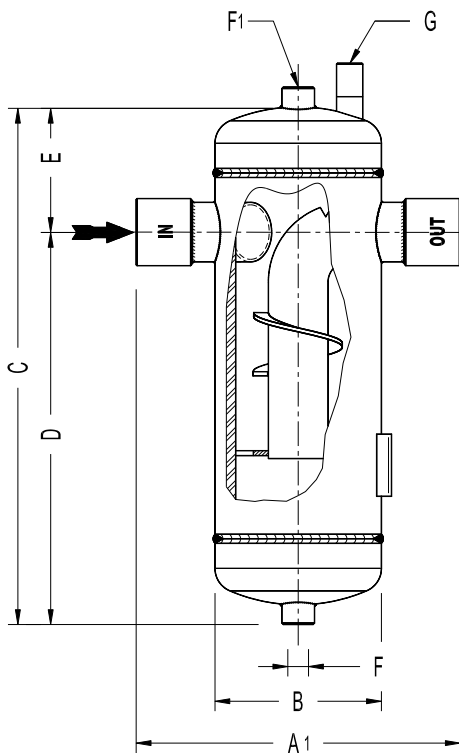

Version EVH

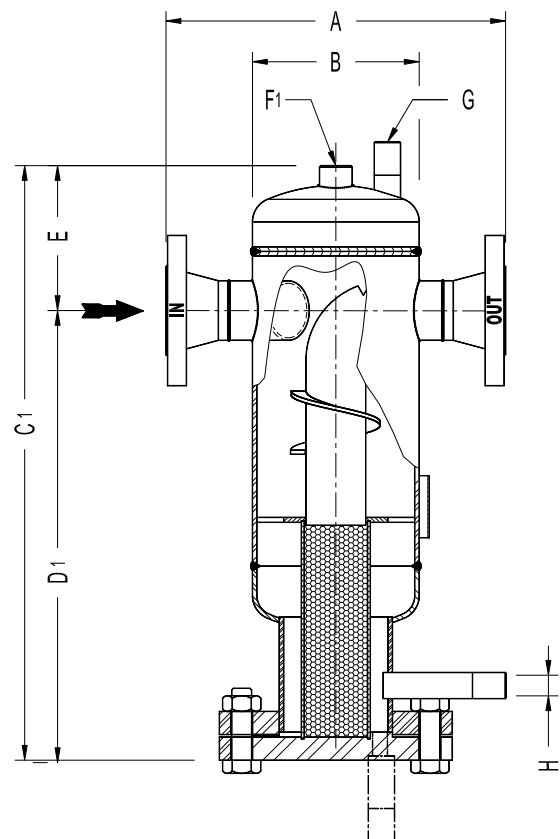

F	Drain connection
F1	Automatic air eliminator connection
G	Manual start up air drain connection
H	Strainer drain connection